

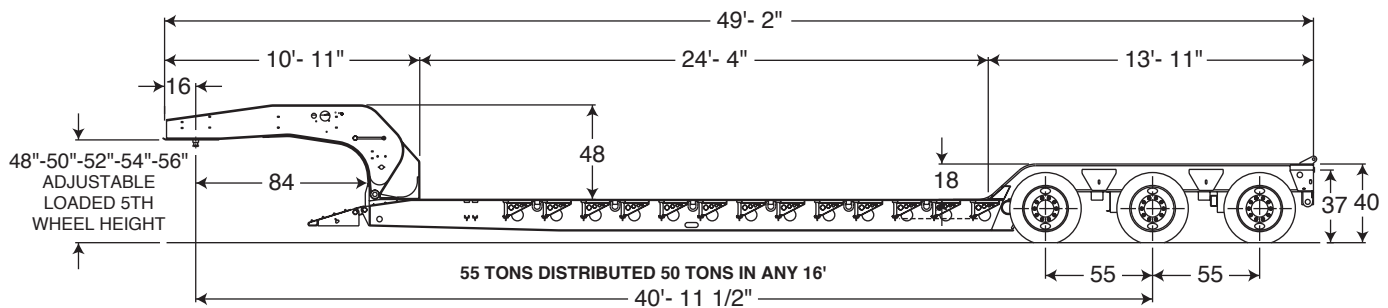

# SPECIFICATIONS

## 50/55 Ton Trailer

### ETNYRE BLACKHAWK CLASSIC SERIES RTN55ETD3 (5055P SERIES)



- General:** 50/55 ton capacity, three axle, non-ground engaging hydraulic removable gooseneck, lowbed trailer for hauling various construction equipment not to exceed 110,000# distributed or 100,000# in any 16' of deck.
- Gooseneck Type:** Hydraulic removable, non-ground engaging, pin and stirrup connection, high lift scraper neck design w/aluminum top cover plate.
- Gooseneck Travel:** 35" gooseneck travel, (21" up; 14" down) with built in adjustable travel height feature for fifth wheel or road clearance adjustment (2" up or 6" down).
- Gooseneck Support Cylinder:** One (1) 3-1/2" diameter, 12" stroke adjustable hydraulic support cylinder to support gooseneck when detaching to eliminate blocking; with control on drivers side.
- Fifth Wheel Height:** 50" Loaded; adjustable 48", 50", 52", 54", 56" without shim blocks.
- Swing Clearance:** 84" Radius minimum (16" Kin Pin setting).
- Hydraulic Power:** From tractor wet kit (P.T.O.). Optional: Plumbed for dual system including tractor wet kit/P.T.O. and power package operation.
- Hydraulic Lift Cylinders:** Two (2) 8" diameter, 20" stroke double acting hydraulic cylinders mounted horizontally in gooseneck upper frame work with control on drivers side.
- Kingpin:** Standard 2" SAE approved mounted in 5/16" 5th wheel plate.
- Gooseneck to Deck Connection:** 2-Vertical teardrop castings on gooseneck to accept (2) 3-1/2" diameter horizontal pins at front of deck. Cross shaft is 3" dia. Stressproof (100,000 min. yield). Deck has alignment guide for gooseneck self-alignment to deck. Air actuated vertical lock pin gooseneck to deck.
- Platform Length:** 24'-4" (Clear, unobstructed).
- Platform Width:** 8'-6" (102").

<b>Deck Construction:</b>	(4) 16" deep/full length I-Beams; 100,000 p.s.i. flanges (fully cambered beams).
<b>Crossmembers:</b>	One (1) piece junior I-beams M10" x 9# pierced through mainbeams on 20" centers.
<b>Outriggers:</b>	12" Swinging and removable type w/double hook-on removable in the first position.
<b>Deck Height:</b>	22" Loaded; adjustable 16", 18", 20", 22", 24". @front of deck (depends on tractor loaded fifth wheel height)
<b>Road Clearance:</b>	6" Loaded; adjustable 0", 2", 4", 6", 8". @front of deck (depends on tractor loaded fifth wheel height)
<b>Lash Rings:</b>	Twelve (12) 1" forged D-rings, bent style 6 each side of deck.
<b>Lashing Slots:</b>	Four (4) - One (1) on bottom side outside edge of bolsters.
<b>Flagholder Slots:</b>	Six (6) - One (1) on each end of bolsters and half bolsters.
<b>Decking:</b>	1-1/2" Apitong, outside of mainbeams attached by self tapping screws.
<b>Ramps:</b>	31" Front folding ramps steel w/traction bars.
<b>Rear Loading Features:</b>	41° sloped ramp ahead of tires, wide center drop bolsters between axles, rear loading drop bolster after 3rd axle.
<b>Suspension:</b>	Ridewell air ride suspension with manual +3"/-3" height adjustment in 1-1/2" increments and manual exhaust valve.
<b>Axles:</b>	Three (3) 22,500# capacity (full width) with 5/8" wall on 55" axle centers. Override chains on all axles.
<b>Wheels:</b>	Steel disc, hub piloted type, painted white, outboard mount with oil seals.
<b>Tires:</b>	(12)-255/70R 22.5 (H) 16 P.R. Radials.
<b>Brakes:</b>	16-1/2" x 7" air with automatic slack adjusters, spring brake chambers on center axle. Brakes rated at a minimum of 20,000# per axle.
<b>Anti-Lock Brakes:</b>	None (trailer exceeds 120,000# GVWR)
<b>Boomwell:</b>	Recessed boomwell w/xtra low 1 <sup>st</sup> crossmember (open) over axles #1 , #2 & #3 and rear half bolster.
<b>Lights and Wiring:</b>	Truck-Lite® L.E.D. sealed system.
<b>Paint:</b>	Shot blast, clean, prime, paint (with 2-part urethane) black, red, or yellow finish.
<b>Bucket Trough:</b>	Last 3 crossmembers in deck. Covered with 1/4" steel plate.
<b>Frame Reinforcement:</b>	For future close coupled 4th axle.
<b>Top Flange Reinforcement:</b>	Top flange outside main beams.
<b>Mudflaps:</b>	Rubber type rear of axle #3