

# IT'S THE TRUCK THING

## THE DISTRIBUTOR TRUCK

The distributor is designed to apply a controlled and metered application of bituminous material. The unit of measurement for product "on the ground" is in gallons per square yard (gal/yd<sup>2</sup>). Distributors are typically used to apply applications from 0.05 gal/yd<sup>2</sup> up to 1.0 gal/yd<sup>2</sup>.

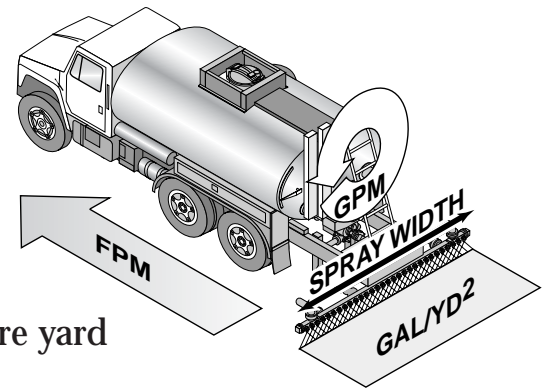

Three important features need to be considered.

- #1 Desired Application Rate – gallons per square yard (gal/yd<sup>2</sup>)
- #2 Width of Spray – Feet
- #3 Forward Ground Speed – Feet Per Minute (FPM)

Items #1 and #2 are determined by the job requirements. This booklet is directed toward Item #3 – the truck speed.

---

## THE VARIABLES

---

- Engine-variable RPM
- Transmission – variable gearing selections – automatic vs manual
- Hydrostatic pump – variable displacement - married to engine RPM, affected by PTO ratio.

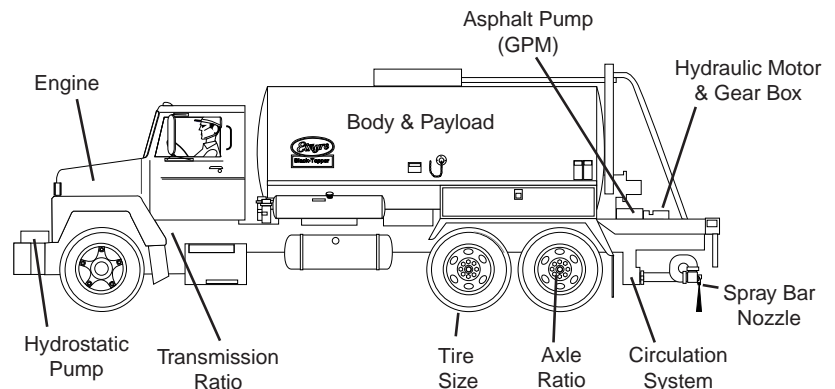

- Hydrostatic motor with gearbox reducer-various ratios and displacements
- Asphalt pump – variable output zero to 400 gallons per minute
- Spray bar width – variable width – 1' to 24'
- Spray bar nozzle – different sizes available
- Tire – different sizes
- Rear axle – optional gear ratios, single speed, two speed
- Circulation system – the plumbing between the asphalt pump and spray nozzle

## THE PRINCIPLE

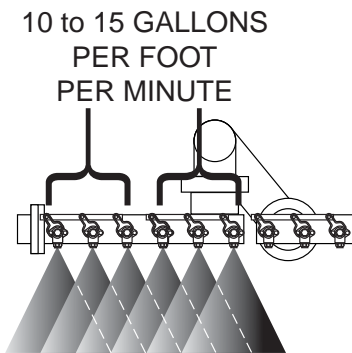
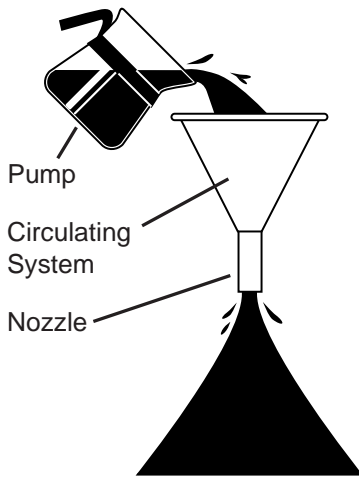

1. The circulation and spray bar system has limits as to the maximum volume that can be pushed through the system by the pump at any given moment.

Faster forward ground speeds or heavier application rates require higher and higher asphalt flow rates to attain target application rates.

2. The asphalt pump's maximum rating is 400 gallons per minute and is rarely the limiting factor.

3. During "normal" operating conditions the spray bar is designed to handle about 10 to 15 gallons per minute per foot\*.

12 foot @ 10gal/ft = 120 GPM (@ 15gal/ft=180 GPM)

20 foot @ 10gal/ft = 200 GPM (@ 15gal/ft=180 GPM)

\*This can be adjusted some by larger or smaller nozzle selection.

### The Twist -

- The asphalt pump output also varies so that the application rate stays constant throughout changes in truck speed.

↑	FPM =	↑	GPM		↑	SPRAY WIDTH=	↑	GPM
↓	FPM =	↓	GPM		↓	SPRAY WIDTH=	↓	GPM

### The Requirement -

- To maintain constant application rate throughout changes in forward ground speed (FPM) and spray bar width.

---

## THE PROBLEM

---

If a chassis is geared too fast, at its slowest forward ground speed, the required volume of material may be too high to be pushed through the system.

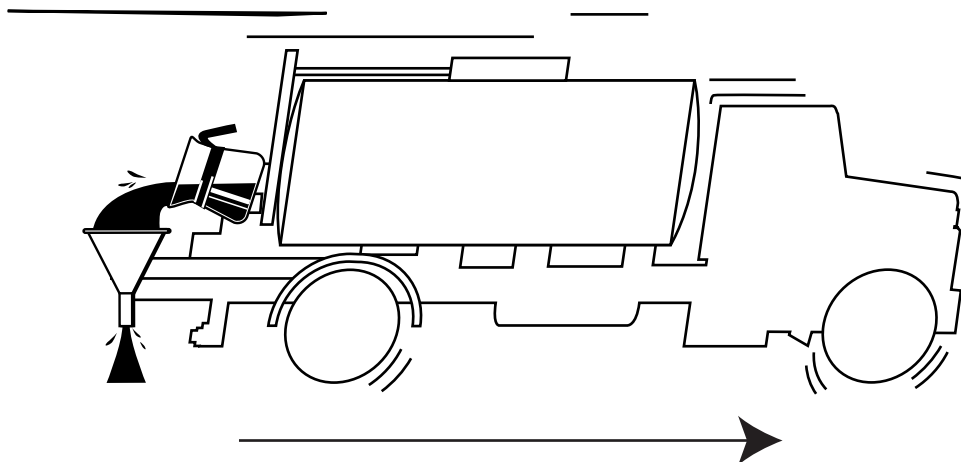

### What Is A Good Truck?

Consider the following and ask questions if there is any uncertainty:

### What Are You Planning To Do With It?

- Shooting light applications such as tack @  $.05 \text{ gal/yd}^2$  can be done with higher speed trucks.
- Shooting heavy applications such as prime @  $.60 \text{ gal/yd}^2$  requires a slower truck.

### Rule Of Thumb! (FPM @ 1200 RPM)

- 100-200 FPM . . . great gearing for most applications (1.0 to 2.0 MPH).
- 200-300 FPM . . . OK for most applications (2 to 3.5 MPH).
- 300-UP FPM . . . marginal for heavy applications, may be ok for tack (3.5 MPH and up).

## THE PROBLEM

- **TRUCK CHASSIS THAT ARE GEARED TOO 'FAST' MAY NOT BE ABLE TO GO SLOW ENOUGH TO SPRAY THE HEAVIER APPLICATIONS.**
- We measure the low side in feet per minute (FPM) assuming engine RPM of 1200 RPM.
  - 2-speed rear axles help by providing a slower gear without giving up highway travel speed.

### The Math

$$\frac{1200 \text{ RPM}}{1 \text{st Gear Ratio} \times \text{Rear Axle Ratio}} \times \text{Tire Factor} = \text{FPM}$$

(varies with size)

### EXAMPLES (all geared for 60+ MPH top speed with 11R22.5 tires)

- Typical 5 speed manual transmission with 2-speed rear axle:

$$\frac{1200}{(7.52) (6.80)} \times 10.56 = 247 \text{ FPM (2.8 MPH)}$$

- Typical "Multi-speed" transmission (eg. Fuller RT8608L) with single speed rear axle:

$$\frac{1200}{(17.21) (4.11)} \times 10.56 = 179 \text{ FPM (2.0 MPH)}$$

**Automatic transmissions** (CAUTION - automatic transmissions are fast and are best suited for tack):

- Allison 3000RDS with single speed rear axle:

$$\frac{1200}{(3.49) (7.21)} \times 10.56 = 503 \text{ FPM (5.7 MPH)}$$

- Allison 3000RDS with single speed rear axle:

$$\frac{1200}{(4.59) (7.21)} \times 10.56 = 383 \text{ FPM (4.4 MPH)}$$

Although trucks may run slower due to torque converter slippage, this is impossible to control as the world is not flat.

Eaton Fuller does provide a two speed auxiliary transmission which can be ordered or installed in most chassis and provides a great solution for marginal situations.

## GENERAL TRUCK REQUIREMENTS BY TANK SIZE

SIZE			TRUCK		
Nominal Gallonage	Tank Oval Size	Useable c.a./c.b.	Front G.A.W.R.	Rear G.A.W.R.	Total G.V.W.R.
1000	47x78x104	84 ca	8,100	17,500	25,600
1250	47x78x122 47x78x128	102 ca 108 ca	9,000	17,500	26,500
1500	53x88x122 50x83x134 47x78x146 47x78x152	102 ca 108 ca 120 ca 126 ca	9,000	19,000	28,000
1750	59x89x122 53x88x137 53x88x140 50x83x152	102 ca 108 ca 120 ca 126 ca	10,000	21,000	31,000
2000	53x88x146 59x89x140	120-126 ca 120 ca	12,000 12,000	21,000 23,000	33,000 35,000
2250	59x89x158	108 ca*	12,000	34,000	46,000
2500	59x89x176	120-126 ca*	12-14,000	34,000	46,000
3000	65x90x186	132-138 ca*	16,000	34,000	50,000
3500	70x92x182	132-138 ca*	16,000	40,000	56,000
4000	70x92x212	152 ca*	18,000	44,000	62,000

\* Tandem Axle

# CHASSIS

## Important Chassis Information

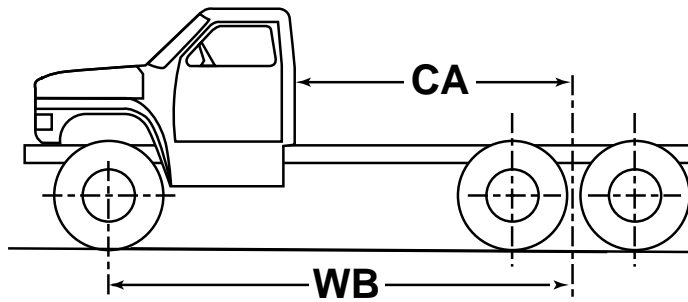
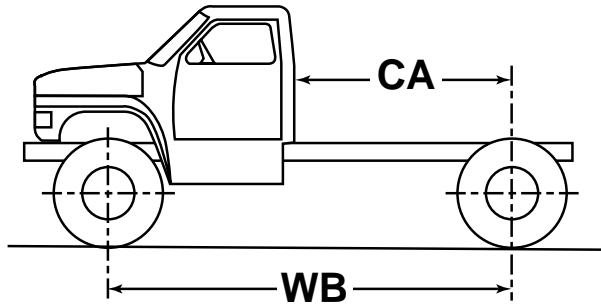

- Front Crankshaft Opening
- Cab to Axle (useable)
- Wheel Base
- GVWR
- GAWR Front
- GAWR Rear
- Transmission make/model
- Rear Axle Ratio

## Etnyre Spray Bar Nozzles

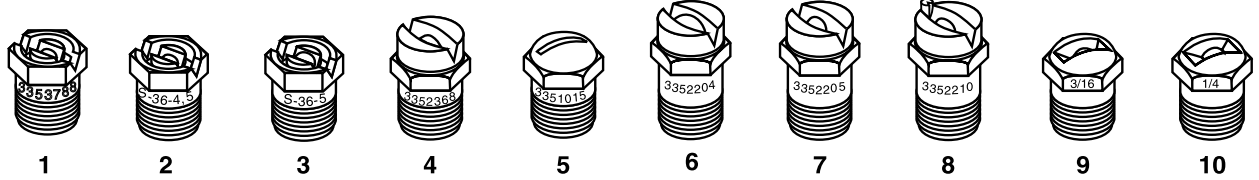

3353788    3351008    3351009    3352368    3351015    3352204    3352205    3352210    3351014    3351010

Ref.	Part No.	Description	Application Per Square Yard	Application (Metric) Liters Per Square Meter	Flow Gallons Per Minute Per Foot
1	3353788	V Slot Tack Nozzle	.05 - .20	.19 - .75	3.0 to 4.5
2	3351008	S36-4 V Slot	.10 - .35	.38 - 1.30	4.0 to 7.5
3	3351009	S36-5 V Slot	.18 - .45		7.0 to 10.0
4	3352368	Multi-Material V Slot	.15 - .40	.57 - 1.50	6.0 to 9.0
5	3351015	3/32" Coin Slot	.15 - .40	.57 - 1.50	6.0 to 9.0
6	3352204	Multi-Material V Slot	.35 - .95	1.30 - 3.60	12.0 to 21.0
7	3352205	Multi-Material V Slot	.20 - .55	.75 - 2.08	7.5 to 12.0
8	3352210	End Nozzle (3352205)	.20 - .55	.75 - 2.08	7.5 to 12.0
9	3351014	3/16" Coin Slot	.35 - .95	1.30 - 3.60	12.0 to 21.0
10	3351010	1/4" Coin Slot	.40 - 1.10	1.50 - 4.16	15.0 to 24.0

---

## QUICK GUIDE

---

### Max Application Rate (Gal/Yd<sup>2</sup>)

Gearing*	@15 Gal Per Foot of Spraybar	@Max Asphalt or Hyd Pump Capacity	Truck Speed (FPM)
20	.21	.27	634
25	.27	.34	507
30	.32	.40	422
35	.37	.47	362
40	.43	.54	317
45	.48	.61	282
50	.53	.67	253
55	.59	.74	230
60	.64	.81	211
65	.69	.88	195
70	.75	.94	181
75	.80	1.01	169
80	.85	1.08	158
85	.91	1.15	149
90	.96	1.21	141

\*Gearing = 1<sup>st</sup> Gear Ration X Rear Axle Ratio (e.g. Allison 3500 RDS with 4.59 1<sup>st</sup> gear and rear axle with 6.50 ratio provides "Gearing" of 4.59 X 6.50 = 29.8)

#### Assumptions

- 16' bar
- Std hyd pump/motor
- 1200 engine RPM
- FEPTO drive